



Frontier Services
Serving Outback Australia



GUIDE TO THE EVENT

for

**COMPETITORS, SERVICE CREWS
AND OFFICIALS**



GUIDE TO THE EVENT

SECTION A - GENERAL

- A1 MESSAGE FROM THE EVENT DIRECTOR
- A2 EVENT SPONSORS
- A3 THE TEAM BEHIND THE TRIAL
- A4 SOME DO'S AND DONT'S TO OBSERVE
- A5 WEATHER AND ATTIRE
- A6 OVERALL SCHEDULE OF ACTIVITIES
- A7 HYDRATION
- A8 CAMS INSURANCE
- A9 START ORDER
- A10 OFFICIAL MAPS

SECTION B – THE COURSE

- B1 OVERVIEW OF COURSE
- B2 SUMMARY OF DISTANCES
- B3 REFUEL INFORMATION

SECTION C: FUNCTIONS

- C1 PRE-EVENT BRIEFING
- C2 WELCOME FUNCTION
- C3 START OF EVENT
- C4 FINISH OF EVENT
- C5 PRESENTATION FUNCTION

SECTION D: PRE-EVENT ACTIVITIES

- D1 EVENT HEADQUARTERS IN FORBES
- D2 COMPETITORS RELATIONS OFFICER
- D3 DOCUMENTATION
- D4 SCRUTINY
- D5 VEHICLE ODOMETER CHECK COURSE

SECTION E: DURING-EVENT ACTIVITIES

- E1 TRIAL HEADQUARTERS
- E2 OFFICIAL NOTICE BOARDS
- E3 MEALS
- E4 ROAD BOOKS/SERVICE CREW INSTRUCTIONS
- E5 ROAD CARDS
- E6 INJURIES/PROPERTY DAMAGE – INCIDENT REPORT FORM
- E7 GOSSIP/PUBLICITY INFORMATION FORM
- E8 COURSE CREWS
- E9 OVERNIGHT STOP PROCEDURES
- E10 LATE TIME LIMITS
- E11 REFUELLING
- E12 SERVICE CREWS/SERVICING
- E13 FOREGOING THE COMPETITION/WITHDRAWAL FROM THE EVENT
- E14 SCORES AND RESULTS
- E15 SAFETY
- E16 DUST MASKS
- E16 ON-BOARD CAMERAS
- E18 GATES
- E19 PUBLICITY
- E20 MERCHANDISE

ATTACHMENTS

- Map of Forbes
- Frontier Service Merchandise order form



GUIDE TO THE EVENT

The information set down in this document is intended as a guide to competitors, service crews and officials involved with the event. This information does not supersede the Supplementary Regulations and subsequent Bulletins and therefore cannot be used as the basis for a protest. If there is a conflict between this information and the regulations, the latter takes precedent.

SECTION A - GENERAL

A1: MESSAGE FROM THE EVENT DIRECTOR

Writing this with just 14 days until the Prologue is a little daunting. The 25 stages are in place and will test the three elements that the event has been put together to test: Driver, Navigator and Car. From the Fat Lady Sings at 4km to the Pilliga stage at 87km and just on 30% of competition the motorsport side is well catered for. The social side has not been overlooked with not too many early mornings or late end of days.

The Frontier Services breakfasts that were a great success last year are again on the menu and will be available one hour prior to your departure each morning. It is also an opportunity for a time to relax and discuss yesterday's exploits.

The Welcome and Presentation functions, the BBQ at Coonabarabran and the many lunches also allow you time to "smell the roses" and enjoy life. Do not take it too seriously - we are here for a good time not a long time.

Although we have a disappointing number of entries, there is a lot of quality. The competition will be strong with the top four placegetters from last year entered and a couple of contenders who had mechanical issues are back to demonstrate their true potential.

This event would not have been possible without the cooperation of Forests NSW. It is becoming extremely difficult to find competitive sections and a total of 19 forests are being used on this event.

Thanks also to our Clerk of Course Tom who ensures that all the i's are dotted and the t's crossed. Phil Rainer has again demonstrated his valuable skills in organising the overnight stops and the many other requirements that make the event successful.

We just have to pray that the rain stops and the sun shines for the next two weeks.

I trust that we all get out of the event what we want and enjoy the experience along the way.

Phil Bernadou

A2: EVENT SPONSORS

Naming Rights Sponsor - Frontier Services

Again we are delighted in having Frontier Services as our naming rights partner. One of the highlights of last year's event was the morning breakfasts. It gave a relaxing informal gathering to consume a hearty meal before the rigors of the day.

Frontier Services is a charity and agency of the Uniting Church that grew out of the pioneering work begun in 1912 by the Rev John Flynn ('Flynn of the Inland').

Frontier Services today is the major provider of aged care, health and community services and pastoral support to people in Outback Australia, working with people across 85 per cent of the continent in regional centre's, Aboriginal communities, isolated properties and mining sites.

It is the only organisation, public or private, providing these services across the whole of remote Australia and needs to raise millions of dollars each year through donations to support provision of critical services.

Frontier Services' goal is to work with and empower communities and individuals to overcome the disadvantages of living in remote locations.

One of the organisation's recent initiatives is its Outback Links programme. Outback Links aims to reduce isolation and disadvantage in Outback Australia by linking appropriately skilled and gifted volunteers with outback people, who could use a helping hand.



Peter Lehmann – Official Wines of the Trial

Peter Lehmann Wines is one of Australia's most respected and innovative winemakers, creating wines that delight wine lovers around the globe.



Winemaking operations are carried out at a single site located near Tanunda, in the heart of the internationally famous Barossa Valley, South Australia.

Since its founding in the Barossa Valley in 1979, Peter Lehmann Wines has cemented its place as one of Australia's most respected and innovative winemakers, and since 2003 it has been a member of the Hess Group, which also includes [The Hess Collection Winery](#) in the Napa Valley, [Glen Carlou](#) in South Africa and [Bodega Colomé](#) in Argentina.

Peter Lehmann Wines will be enjoyed exclusively at the Official Welcome function of the 2010 Frontier Services Classic Outback Trial in Forbes and at the event's Gala Presentation Dinner in Forbes.

Telstra Country wide – Official telecommunications partner



The 2010 Classic Outback Trial is again relying on Telstra Country Wide to deliver the satellite, mobile and land-line communication services that are essential for the safe and effective running of a major motoring event in remote regions of Australia.

The unrivalled coverage offered by Telstra's Next G network makes it possible for (up to date) event information to be made available to participants and supporters at a speed that would have been unthinkable to the organisers of the previous 13 Round Australia trials.

A3: THE TEAM BEHIND THE TRIAL

EXECUTIVE COMMITTEE

Promoter/Trial Director	Philip Bernadou	pora1@bigpond.net.au	0412 498 602
Clerk of Course	Tom Snooks	kemdot@iprimus.com.au	0428 165 275
Assistant Clerk of Course	Phil Rainer	prainer@bigpond.net.au	0418 517 385
Publicity/Promotion	Michael Browning	michael@browning.com.au	0418 324 328

HEADQUARTERS/OVERNIGHT STOPS

Clerk of Course	Tom Snooks
Assistant to Clerk of Course	Kevin Shaw
Competitor Relations Officer	Kevin Shaw
Results Manager	Garry Searle
Results Manager's Assistant	Alex Ross
Chief Scrutineer	Grahame Palmer
Overnight Stop Officials/Scrutineers	Noel Claridge, Jeff Lomman
Publicist	Michael Browning
Photographer	John Douch
MC (Presentation)	John Emery

COURSE CREWS

Set Up Car 1	Phil Bernadou, Louise Bernadou, Keith Morris (Checker)
Set Up Car 2	Phil Rainer, Carlie Rainer
Sweep	Jim Reddiex, Ian Reddiex, Alex Ross, Jenny Ross
Recovery 1	John Hammond, Elaine Hammond

ROAD CREWS

Crew 1	A	John Quayle, Julie Quayle
Crew 2	F	Peter Fraser, Marg Fraser
Crew 3	A	Pat Hetherman, Ann Hetherman, Sheridan Hetherman & Cailin Williamson
Crew 4	B	Ron Brown, Marcia Brown
Crew 5	C	Bill Bennett, Joan Bennett
Crew 6	C	Steve Hollowood, Chris Jones
Crew 7	B	Peter Lewis-Williams, Judi Lewis-Williams
Crew 8	D	David Johns, Sue Johns
Crew 9	D	Les Shadwick, Jane Shadwick
Crew 10	E	Ian Ellis, Garry Harrowfield, Barry Edmonds
Crew 11	E	Allan Wells, Ray Stubbs

FIV TEAMS

FIV 1	Steve Gaggin, Chris Benjamin
-------	------------------------------

CAMS OFFICIALS

Steward	Allan Denney (Chief)
Steward	John Sendall
Checker	Keith Morris

A4: SOME DO'S AND DONT'S TO OBSERVE

DON'T speed on public roads. Keep within the speed limit and respect the applicable traffic laws. Speeding competitors are liable to incur the normal civil traffic offence penalties as well as event penalties under Supplementary Regulation Article 616.2.

DO close gates when required to do so – take notice of the 'close' or 'open' signs.

DON'T ever leave an overnight stop without sufficient water.

DO show courtesy to other road users, and to locals in the area through which we pass – after all, they live there and we might want to return some day. Also, remember your car is 'marked' with decals so they know who you are.

DON'T consume alcohol during the competition, or carry firearms – you will be excluded under Supplementary Regulation Articles 114 and 115.

DO obey the instructions of the officials – this will make for the conduct of a smoother event.

DON'T litter – be tidy and put your rubbish in containers and then into an appropriate bin. Never bury your rubbish as animals will just dig it up and spread it around.

DO report any incident or accident with another vehicle, stock or property. Use the event's Incident Sheet and hand it in at the Trial Headquarters (or to the Competitor Relations Officer).

DON'T drop oil anywhere – put it in a container and dispose of it properly at the next service station or at the appropriate container at an overnight stop.

DO consult the Competitor Relations Officer for help with any problem.

A5. WEATHER AND ATTIRE

The average statistics for the weather in September as:

Location	Temperature		Rainfall	
	Max	Min	mm	No Days
Forbes	16	3	38	5
Dubbo	17	3	44	5
Coonabarabran	17	1	53	6

Remember these are averages so it could be considerably warmer or colder on the day.

The weather will be the warmest since last summer and, with the coldish nights and mornings, you need to dress accordingly. Best to have clothing that can be 'peeled off' as the day warms and put on as the evening (or morning) gets colder.

It is very important to make sure that you have suitable headgear – a wide brim hat is essential as you may have to stand in the sun without much shade if you have a car problem in some parts of the country – a cap may not be sufficient, and certainly you won't want to stand around in your safety helmet!! And make sure you have sun screen lotion amongst your kit in the car.

A6. OVERALL SCHEDULE OF ACTIVITIES (subject to change due to changing circumstances)

DAY	DATE	TIME	ACTIVITY	TOWN	LOCATION
Sat	21/8	1200-2000	Documentation (at issued report times)	Forbes	Plainsman Motel, Sherriff Street
Sat	21/8	1300-1400	Scrutiny (at allocated times)	Forbes	Jelbart Dawson Ford, Rankin Street
Sun	22/8	0800-1200	Documentation (at issued report times)	Forbes	Plainsman Motel, Sherriff Street
Sun	22/8	0830-1300	Scrutiny (at allocated times)	Forbes	Jelbart Dawson Ford, Rankin Street
Sun	22/8	1400-1500	Prologue	Forbes	Forbes Showgrounds
Sun	22/8	1800-1830	Competitors/Service Manager Briefing	Forbes	Town Hall, Harold Street
Sun	22/8	1800	Start order, vehicle class postings	Forbes	Town Hall, Harold Street
Sun	22/8	1845-1930	Welcome Function	Forbes	Town Hall, Harold Street
Mon	23/8	0800-0830	Competitors report to start location	Forbes	Town Hall, Harold Street
Mon	23/8	0800-0900	Frontier Services Breakfast	Forbes	Town Hall, Harold Street
Mon	23/8	0900	First vehicle starts event	Forbes	Town Hall, Harold Street
Mon	23/8	1205-1330	Lunch and service	Condobolin	Showground
Mon	23/8	1445	First vehicle arrives end of Day 1	Forbes	Showgrounds, off Camp Street
Tue	24/8	0800-0900	Frontier Services Breakfast	Forbes	Forbes Gordon Duff Drive
Tue	24/8	0900	First vehicle starts Day 2	Forbes	Forbes Gordon Duff Drive
Tue	24/8	1300-1430	Lunch and service	Peak Hill	Peak Hill football ground
Tue	24/8	1500	First vehicle arrives end of Day 2	Dubbo	Beside Ollie Robbins Oval
Wed	25/8	0800-0900	Frontier Services Breakfast	Dubbo	Beside Ollie Robbins Oval
Wed	25/8	1130	First vehicle starts Day 3	Dubbo	Beside Ollie Robbins Oval

Wed	25/8	1430	First vehicle arrives end of Day 3	Coonabarabran	Showground, off Newell Highway
Thu	26/8	1700	Partial Provisional Results posted	Coonabarabran	HQ – Acacia Motor Lodge
Thu	26/8	0800	First vehicle starts Day 4	Coonabarabran	Showground, off Newell Highway
Thu	26/8	0700-0830	Frontier Services Breakfast	Coonabarabran	Showground, off Newell Highway
Thu	26/8	1200-1415	Lunch and service	Aloes	Picnic Area
Thu	26/8	1415	First vehicle arrives end of Day 4	Coonabarabran	Showground, off New England Highway
Fri	27/8	0630-0830	Frontier Services Breakfast	Coonabarabran	Showground, off New England Highway
Fri	27/8	0730	First vehicle starts Day 5	Coonabarabran	Showground, off New England Highway
Fri	27/8	1200-1410	Lunch and service	Burdenda	Burdenda Shearing shed
Fri	27/8	1715	First vehicle arrives end of Day 5	Forbes	Forbes Showgrounds
Sat	28/8	0700-0800	Frontier Services Breakfast	Forbes	Forbes Showgrounds
Sat	28/8	0800	First vehicle starts Day 6	Forbes	Forbes Showgrounds
Sat	28/8	1030-1130	Lunch and service	Ootha	Burrawang West Retreat
Sat	28/8	1304	First vehicle arrives; service; impound	Forbes	Forbes Showgrounds
Sat	28/8	1500	Fat Lady Sings section	Forbes	Forbes Showgrounds
Sat	28/8	1630	Provisional Results posted	Forbes	HQ – Plainsman
Sat	28/8	1900-2300	Presentation Function	Forbes	Forbes Serviceman's Function Centre

A7. HYDRATION

Geoff Becker and Graham McGrath of MotorSport Safety & Rescue Pty Ltd have provided this article on maintaining hydration.

Did you know that a loss of fluid, equal to 2% of body mass is sufficient to cause significant decrease in performance and increases the risk of symptoms such as nausea, vomiting, diarrhoea and other GIT symptoms?

Typically athletes, in high intensity exercise in hot conditions, can lose 2 -3 litres per hour. In some of the hot rallies in Asia there have been examples of crews losing up to 4 kilos each per day. Once lost, it is very difficult to reverse. As a general rule we should be aiming to keep fluid loss to less than 1kg

Maintaining hydration can be achieved by adopting a planned approach during the event, by drinking plenty of suitable fluids. We recommend that for every litre of water consumed, you follow-up with a 500ml electrolyte drink - *it is important to find an electrolyte drink that you find palatable.*

There are two simple ways of ensuring that you are drinking enough and they are:

- If your urine is clear (*this is a reliable indicator of sufficient fluid intake*)
- You should urinate several times a day
- If practical, weigh yourself at the start and the finish of each day to check on any weight loss.

The FIA Institute of Motor Sport Safety recommends avoiding:

- Aerated Drinks
- Large quantities of fruits
- Large amount of confectionery
- Alcohol (*proven as a diuretic and will increase fluid loss*)
- Foods which are difficult to digest; melon, cucumber, cabbage, onion, spices, rich, or fried foods.

The Institute recommends:

- Non – aerated water
- Fruit juice
- Energy drinks
- Sugars absorbed slowly (pasta, rice, bread)
- Dried fruit

*A note on coffee – the consumption of caffeine has now **NOT** been proven to impact on dehydration.*

As a means of early identification drivers, navigators and service crew should take notice of each others' mental and physical wellbeing, subtle changes can be an early indicator of the onset of dehydration.

Treatment

Avoid becoming dehydrated. Cases of dehydration require 150% of fluid loss to be replaced over a 2-6 hour period - this is not easy to achieve during the event.

A8. CAMS INSURANCE

Refer to SR205. Remember:

- The property damage excess payable by a competitor is \$1,200.
- Up to 5 additional units of personal accident insurance are available to all crew members. For details see the CAMS website.

A9. START ORDER

Day 1

The start order for Day 1 will be based on the Prologue event with the fastest time starting car one and will be posted on the Official Notice Board at 1800 on Sunday 23 August. Vehicles will leave the start in Forbes at one minute intervals, and then start the first competitive section at two minutes intervals.

Posting of Start Order During Event

Re-start times will be posted progressively during the processing of the road cards, and the progressive start order for the following Day will be posted as the road cards have been scored.

This progressive list will provide an indication of the *approximate* starting time the next day. Naturally, these times are subject to change as later competitors arrive and results are tallied. Nevertheless, it gives a good idea of the approximate start order so competitors can retire for the night without waiting for the final print out.

Upon completion of processing, the final start order will be posted on the Official Notice Board and it is a good practice to always re-check the start order first thing in the morning and make sure you allow plenty of time to re-start at your correct time

A10. OFFICIAL MAPS

The official maps, to be issued at documentation in Forbes, are:

NRMA Map 5 – Central North West covering New England and Cowra to Tenterfield

NRMA Map 7 – Murray, Riverina & Far West

SECTION B – THE COURSE

Summary of Schedule Start/Finish Times – First Vehicle (subject to change at any time):

(Note: 'Finish Time' is without late running and includes refuelling at the end of the Day)

Day	Day	From	Time Start	To	Time Finish
1	Mon	Forbes	0900	Forbes	1445
2	Tue	Forbes	0900	Dubbo	1505
3	Wed	Dubbo	1130	Coonabarabran	1230
4	Thu	Coonabarabran	0800	Coonabarabran	1415
5	Fri	Coonabarabran	0730	Forbes	1645
6	Sat	Forbes	0800	Forbes	1225*

**followed by last stage at Forbes Showground*

B2: SUMMARY OF DISTANCES

Day	No. of Comp Secs	Transport	Competitive	Total	% Comp
1	5	260	101	360	25
2	4	295	116	409	28
3	1	171	17	187	9
4	5	189	188	376	49.7
5	5	489	143	631	22
6	5	198	99	294	33
Total	21	1,601	664	2,258	29

B3: REFUEL INFORMATION

Day	Refuel 1		Refuel 2		Refuel 3		To Finish		Total
	Total	Comp	Total	Comp	Total	Comp	Total	Comp	
1	162	40	67	31			131	30	360
2	174	64	79	11			156	41	409
3	61	17					120		187
4	61	29	70	32	141	87	101	40	376
5	114	21	254	59			159	62	631
6	123	25					166	54	294

SECTION C: FUNCTIONS

C1: PRE-EVENT BRIEFING

A written briefing will be issued at Documentation.

C2. WELCOME FUNCTION

The Welcome Function, courtesy of the Forbes Shire Council, will be conducted as follows:

Sunday 22 August

1800-1930 hours

Forbes Town Hall

Cnr Newell Highway and Harold Street

All competitors, service crews and officials are invited to attend the Welcome Function. There will be no entry fee. Dress – neat casual.

C3. START OF EVENT

The start of the event will be as follows:

Monday 23 August

0900 hour for first vehicle, other vehicles leave at one minute intervals

Forbes Town Hall

Assembly in Harold Street

Details on time of reporting to the start assembly area and the start procedure will be issued at Documentation. The start order will be posted at 1800 hours on Sunday 30 August.

C4. FINISH OF EVENT

The finish of the event will be as follows:

Forbes Showgrounds

Show Street

Forbes

The first vehicle due at Forbes at 1334; a service period will be available and then the vehicle placed in impound until the arrival of the last vehicle plus late time.

Vehicles will then participate in the last competitive section over approximately four kilometres on a track in the Showgrounds and adjacent areas. Vehicles will be impounded until the last vehicle finishes this section (approx 1550), and released on the orders of the Clerk of Course.

C5. PRESENTATION FUNCTION

The Presentation Function will be conducted as follows:

Saturday 28 August

1900 (pre-dinner drinks) for a 1930 start with a 2300 finish.

Forbes Services Club

41-43 Templar Street

Forbes

Tickets to function:

A ticket for each competitor is included in the event entry fee; the procedure for obtaining the ticket and advising of competitors presence or otherwise at the function will be issued at Documentation. Extra tickets are available at \$75 (includes a three course meal and all drinks except spirits) for service crews, friends and family of competitors. These may be ordered at any time (refer to 'Order Form for Functions Competitors & Service Crews' under 'forms' on the event's website. The latest time for ordering extra tickets is 2000 on Tuesday 24 August at the event headquarters. The evening will be one solely dedicated to competitors and officials, with no *other* entertainment provided.

AWARDS

Competitors are advised that given the smaller field the number of awards will be reduced to the following, as most classes will be amalgamated into one class for each Group (refer SR301.1):

Outright

First Outright Crew
Second Outright Crew
Third Outright Crew

Group

First Historic Rally Car Group Crew
First Classic Rally Car Group Crew
First PRC Group Crew
First Group 4 Crew

Class

The only class wards will be made to:

PRC Group 3A Crew
PRC Group 3B Crew

Team Awards

As per SR901.4.

Special Awards

As per SR901.5.

SECTION D: PRE-EVENT ACTIVITIES

D1. EVENT HEADQUARTERS IN FORBES

The Event Headquarters will be located as follows:

The Plainsman Motel
22 Sheriff Street
02 6852 2466

The Headquarters will officially be open as follows:

Day	Open From	Closed
Sat	1000	2000
Sun	0800	2000
Mon	0800	2000
Tue	0730	0900

Contact details:

Clerk of Course	Tom Snooks	0428 165 275
Assistant to Clerk of Course	Kevin Shaw	0406 407 408

Location		Open	Close
Forbes	Saturday 21st	1000	2000
	Sunday 22nd	0800	2000
	Monday 23rd	0800	2000
	Tuesday 23rd	0800	1000
Dubbo	Tuesday 24th	1400	2000
	Wednesday 25th	0800	1000
Coonabarbaran	Wednesday 25th	1400	2000
	Thursday 26th	0730	2000
	Friday 27th	0700	0900
Forbes	Friday 27th	1300	2000
	Saturday 28th	0700	1900
	Sunday 29th	0900	1000

D2. COMPETITORS RELATIONS OFFICER

The Competitor Relations Officer (CRO) will be basically located as follows:

Saturday/Sunday	around HQ/documentation/scrutiny
Sunday	at the Welcome Function
Monday & each day	at the start of each Day; and at end of each Day control/HQ after that
Saturday	at the finish until 1530 and then the Forbes HQ from 1700

The CRO is available to be contacted on any issue affecting competitors and will deal with the issues and refer to the Clerk of Course (and other senior officials) as necessary. This line of communication allows senior officials to get on with running the event instead of answering questions. However, this does not remove the right for a competitor to seek discussion with the Clerk of Course.

D3. DOCUMENTATION

Documentation will take place as follows:

The Plainsman Motel
22 Sheriff Street
(02) 6852 2466

Competitors must report to documentation PRIOR to reporting to scrutiny, and at the time specified in Bulletin 2. Competitors are reminded of the penalty for reporting late for documentation (SR501.2). At documentation crew members are required to:

- (1) Pay any monies outstanding.
- (2) Ensure that the entry form has been signed by all crew members.
- (3) Present CAMS Competition Licences for the competitor and all crew members.
- (4) Present civil driving licences of crew members who will be driving.
- (5) Provide proof of ownership (and permission to enter the vehicle if a member of the crew is not the bona-fide owner).
- (6) Present the vehicle registration document.
- (7) Present proof of third party insurance for the vehicle (if this is not issued in conjunction with the vehicle registration document).
- (8) Present an "extension" of the "Compulsory Third Party Insurance Policy for Sporting Activities" for vehicles registered in Qld.
- (9) Be issued with crew personal identification ('wrist bands' and 'swingers'), merchandise and vehicle decals.
- (10) Finalise service crew registration.
- (11) Advise if assistance is required for refuelling on Day 4 (see B3 above).
- (12) Medical Questionnaire for FIV Crew
- (13) Frontier Services Breakfast Order

D4. SCRUTINY

Pre-event

Report times for Pre-event Scrutiny will be issued at Documentation, and will take place as follows:

Jelbart Dawson Ford
Cnr Lachlan Street (Newell Highway) and Rankin Street
Forbes
Sat: 1400 to 1700
Sun: 0900 to 1300

Competitors are reminded of penalties for late arrival (SR502.2). Pre-event scrutiny of vehicles will be of a general nature:

- Check of vehicle make and model;
- Engine and chassis numbers agree with those shown on the certificate of registration or permit;
- Apparent conformity of the vehicle to the technical description document and the vehicle category for which it was entered;
- The presence of mandatory safety and emergency items;
- Apparent mechanical reliability;
- Correct placement of organisers decals on the vehicle;
- Acceptable standard of appearance of the vehicle.
- Present a CAMS Vehicle Log Book.

Any vehicle not conforming to the scrutiny or technical regulations, and which is not corrected, or appropriately re-classified, will be denied permission to start the event.

During-event

Vehicles will be checked by scrutineers immediately after booking in at the end of each Day and any issues requiring attention must be addressed and approved by the scrutineers before the crew can start the next Day.

D5. VEHICLE ODOMETER CHECK COURSE

A 5.00km odometer check course has been set by the organisers Forbes, using GPS. This was checked and used during the CAMS course check.

South on Newell Highway from Forbes

0.00 100km/h de-restriction zone sign

5.00 COT marker

Signs showing 'Start ODO' and 'Finish ODO' will be erected by 1000 hours on Saturday 21 August. The check can be used in reverse. See attached Forbes map for location of the check course.

SECTION E: DURING-EVENT ACTIVITIES

E1: TRIAL HEADQUARTERS

Headquarters will be located as follows.

Day	Town	HQ	Address
Mon 23/8	Forbes	Plainsman Motor Inn	Sherriff Street
Tues 24/8	Dubbo	Cattleman's Country Motor Inn	Whylandra Street
Wed 25/8	Coonabrabran	Acacia Motel	Newell Highway
Thur 26/8	Coonabrabran	Acacia Motel	Newell Highway
Fri 27/8	Forbes	Plainsman Motor Inn	Sherriff Street
Sat 28/8	Forbes	Plainsman Motor Inn	Sherriff Street

E2: OFFICIAL NOTICE BOARDS

Official Notice Boards will be located at all the Headquarters. It is the competitor's responsibility to check the notice board for any information that may be issued by the organisers. An Official Notice Board will also be established on the events website. Times, penalties, results and the start order for next Day will be posted on these boards each night.

E3: MEALS

Breakfasts

Frontier Services will be providing a breakfast service as follows:

Monday 23rd Forbes

Tuesday 24th Forbes

Wednesday 25th Dubbo

Thursday 26th Coonabarabran

Friday 27th Coonabarabran

Saturday 28th Forbes

Have your breakfast delivered to you or collect it in the morning – the choice is yours! By purchasing these convenient, healthy and satisfying breakfast options, you will be supporting Frontier Services' Outback Links project and many remote families and communities. So ... sustain yourself and Outback Links at the same time! You can even pre-purchase breakfast for the entire Trial and we will deliver them to you!

Your Breakfast Options:

The Jump Start \$8

Includes: Cereal and milk (choice of Cornflakes, NutriGrain & Light N Tasty)
Berri Multi V Orange juice
Goulburn Valley Two Fruits Diced
Wheelies Cookies
Bowl, serviette, spoon & sugar portions included

This pack can be delivered to your motel the evening prior or collected at the start line in the morning.

The Shock Absorber \$11

Includes: Cereal and milk (choice of Cornflakes, NutriGrain & Light N Tasty)
Berri Multi V Orange juice
Goulburn Valley Two Fruits Diced
Wheelies Cookies
Bowl, serviette, spoon & sugar portions included

****Plus a delicious Egg and bacon roll – cooked fresh by your Outback Links volunteers at the start line!****

Coffee and tea will be provided at the start area each morning plus water; drinks, fresh fruit and snacks will be available for purchase each morning!

If you have any special dietary requirements, please write these on the order form or call Davida on 0428 958 529.

Please return this form with your order (see attached) to the Frontier Services team at the Welcome Function, or at the end of each day's competition!

Lunches

Lunchbreaks are organised each day.

Dinners

It needs to be appreciated that in country towns restaurants/cafes often close around 2000.

E4: ROAD BOOKS/SERVICE CREW INSTRUCTIONS

Road Books

Road books will be issued as follows:

- Day 1 – between 1500 and 1730 on Sunday 22 August at the event's HQ
- Days 2, 3, 4, 5 and 6 – on arrival at the end of the Day and after the vehicle passes scrutiny

The structure of the road book will be:

- Sponsors page
- Day Map of course
- Page with Day descriptions, Day distances, refuel schedule, contact telephone numbers
- Itinerary page
- Page of abbreviations used
- Tulip information page
- Town map of town leaving (if applicable)
- Route instructions
 - rating of difficulty of competitive section (highest degree of difficulty = 5)
 - distance
 - time allowed for section
 - convention route charts, including refuel and meal break information
 - GPS (Global Positioning System) coordinates of all competitive controls are listed
- Competitive section map, with description
- Town map of town entering
- Sketch of compound/servicing/parc ferme area
- End of Day procedure
- Incident, Gossip, Withdrawal/Foregoing the Competition Forms
- Spare road card

You MUST check your road book upon receiving it – all the pages are numbered, which makes for easy checking. If you have an incomplete road book see the CRO.

Service Crew Instructions

The event's service crew instructions will be listed in one book, and this book will be issued with the road books on Sunday 22 August between 1500 and 1800. One set of instructions is issued as part of the entry fee, extra service registration is available for \$50 per set.

E5: ROAD CARDS

A road card will be issued with the road book for each Day and it is the competitor's responsibility to look after the card and hand it in at the end of the Day. If the road card is left behind at a control there is no need to turn back for it. Just continue and use the spare road card in the road book, or Incident Report Form, for officials to record times at controls. If a road card is lost, do the same thing. There is no penalty for losing a card – the only penalty being that the times cannot be computed until the control cards arrive at the end of the Day with the Sweep vehicle. So, please do take care of your card and try to prevent dust from getting on it as it is then difficult to write on.

E6: INJURIES/PROPERTY DAMAGE – INCIDENT REPORT FORM

Competitors are required (under SR 617) to report all incidents involving a member of the public, injury to a competitor, official or spectator, and any damage to a vehicle. Reports are to be made using the official 'Incident Report Form' located in the back of the road book (and available from HQ and the CRO). These forms are to be handed to the CRO or into HQ; or given to an official if the former is not possible.

E7: GOSSIP/PUBLICITY INFORMATION FORM

A 'Gossip/Publicity Information' form will be located in the rear of the road book and you are invited to report any incidents that you see or hear of that may be of interest to the event's publicist.

E8: COURSE CREWS

Section Set Up Crew

Control crews will man the start and finish of each competitive section. There are eleven such crews and they will travel round the course carrying out their specific tasks, and will be fully briefed in their duties and issued with relevant manuals. They will arrive at the start of a section no later than three hours before the first competitor is due, and the crew manning the section finish control will drive through the section and set up advisory signs for competitors and erect any road closure materials. On arrival at the end of the section the control/set up crew declares that section 'yellow', meaning it is set up but not ready for competition. After the last competitor and then 'sweep car' have passed through the start control, the officials manning the start will travel through the section and collect all signs and road closure materials.

Section Check Car

This car will carry the Deputy Clerk of Course who has set the course, as well as the CAMS Course Checker who checked the course with the Deputy in July, when they agreed with how the course is to be set up, with direction signs, caution signs, road closures (manned or with bunting/notice). They will pass through about an hour before the first competitor and will check the set up of the signs and officials and 'seal' the road by placing the road closure materials in place. On arrival at the end of the section the crew declare the section 'green', thus indicating it is ready for competition.

Sweep Car Crew

Travelling immediately behind the last competitor a 'sweep crew' travels through the course and collects all paperwork, closes controls and re-opens any closed road. When this crew reaches the finish of each competitive section it declares the section to be 'black', which means the competition is over.

Recovery Crew

A recovery vehicle will travel behind the field and provide assistance to any crew requiring it. The recovery crews are not obliged to repair cars or tow them, although they may do so at their discretion.

First Intervention Vehicle (FIV) Crew

An FIV manned by paramedics will accompany the event.

E9: OVERNIGHT STOP PROCEDURES

The following is an extract from a road book:

ARRIVAL

Booking into the final control. There is no penalty for booking in early, but you will be penalised if you are late (one min/min). The control official will keep your road card and any forms you wish to hand in.

Scrutiny

Immediately after booking in, scrutineers will look over the vehicle. If all is in order a 'Ready to Start Day' sticker will be placed on the vehicle; if there are any defects these will be advised to you and must be rectified and passed by the scrutineers before you can start the next Day.

Competitor Relations Officer

The Competitor Relations Officer will be located at the arrival location.

Road Book and Service Crew Instructions for Next Day (SR601.1)

These will be issued once you have passed scrutiny. If you are very late and the control is unmanned, the books will be available at HQ.

Impound Area

After the above procedures, other than at the end of Day 6, when vehicles will be placed in an impound at the finish at Forbes, crews are free to take their vehicle wherever they wish.

Reports/Claims/Protest

If you have any reports to lodge or claims to make these MUST be lodged with the Competitor Relations Officer, or with HQ, **WITHIN TWO HOURS** of your booking in at the end of the last transport section.

- Enquiry on any alleged mistake, irregularity or action on the course for today (SR112.2)
- Report on overtaking (SR612.5)
- Refund of compassionate time (SR618 – read this before lodging a claim!!)
- Any accident of any type which results in injury; or damage to another vehicle or property or stock – an Incident Sheet MUST be lodged with the organisers.

E10: LATE TIME LIMITS

Late time limits are advised in a bulletin and in the roadbook.

E11: REFUELLING

Refer to B3 above for the refuel schedule.

E12: SERVICE CREWS/SERVICING

Service Crews

Service Crews are required to be registered with the organisers and the registration form is available on the event's website. The first registration fee is included in the entry fee, additional crews cost \$50.

Service crew instructions, briefing document and service vehicle decals will be issued at Documentation in Forbes.

All service crew members may attend the briefing.

Service crew members are invited, at no charge, to the Welcome Function.

Tickets will be required for the Presentation Function by service crews that cost \$75 each; they may be purchased at Documentation in Forbes, and at any event HQ until 1900 on Tuesday 24 August. No guarantee of tickets can be offered by the organisers after this date due to catering numbers having to be advised to the function caterers.

E13: FOREGOING THE COMPETITION/WITHDRAWAL FROM THE EVENT (SR619)

Competitors are reminded of procedures outlined in SR619.

E14: SCORES AND RESULTS

Study the regs for definitions

Scores (SR802)

Scores (times and penalties) will be calculated as soon as possible and posted on the Official Notice Board at HQ. When a number have been processed (say 20) the scores will be placed on the website. Any enquiry can be lodged with the Competitor Relations Officer.

Results

Days 1 to 4 (copy from Bulletin 1)

Partial Provisional Results will be adopted and will be published at Coonabarabran after the end of Day 3 (Wednesday 25 August). These will be posted on the official results notice board and will cover Day 1 (start) to Day 3 (arrival at Coonabarabran)

- Posted between 2000 and 2100 (if unable to post at this time a notice will be placed on the notice board indicating a new posting time);
- If posted by 2100 competitors have up to 2200 to lodge any protest

Once the above protest times have passed no protest can be lodged at a later time.

Days 4, 5 and 6

Days 4, 5 and 6 provisional results will be posted at the HQ at Forbes at 1630 and will become final results one hour later if no protests are received.

Competitors are reminded that any protests about any mistake, irregularity or action to the prejudice of the competitor must be lodged within two hours of arrival at the end of the Day, or on Day 6 within 10 minutes of the last vehicle arriving at the finish, in which such mistake, irregularity or prejudice occurred. These types of protests CANNOT be lodged in conjunction with the posting of provisional results.

E15: SAFETY DOCUMENT FOR COMPETITORS

Motorsport Safety Rescue is providing the Safety Team, comprising a 'First Intervention Vehicle' (FIV) and two medical staff (doctor and paramedics, both experienced in rallies and outback events) have been established to provide coverage specifically for the competitive sections. On transport sections, the team will assist at accidents, but these are primarily the responsibility of the various state emergency services. All medical services in the vicinity of the route will be advised of the passage of the event.

A Safety Document will be issued with the Day 1 road book in Forbes.

E16: DUST MASKS

Don't forget to include dust masks in your kit.

E17: ON BOARD CAMERAS

This was not covered in the supplementary regulations. However scrutineers will be checking that any camera is safely mounted, using the following criteria.

Cameras and video recorders may be fitted to vehicles. Where the camera and recorder are combined into a unit (Camcorder) the unit must only be fitted to the rollover protection structure or other substantial part of the body shell of the vehicle. It must be mounted inside a safety cradle which fits closely around the body of the unit. The camcorder shall be held in place by a strap held tight by means of self locking fasteners. The strap and cradle may be lightly padded. The cradle shall be constructed as shown in Diagram (X) below and held to the rollover protection by means of a metal clamp and at least two 6mm class 8.8 bolts. Rollover protection type padding is to be placed on the outside of the box/carrier.

Where the camera is a small separate unit (ie a 'lip stick' lens), it need not be fitted inside the cradle described above, but the recorder shall be mounted in the luggage compartment, or where this is impractical (eg. hatchback vehicles), it shall be mounted inside a box made from aluminium of a minimum thickness of 5mm, held down by at least three 6mm diameter class 8.8 bolts. This mounting of any on-board camera shall be inspected and approved by the Chief Scrutineer.

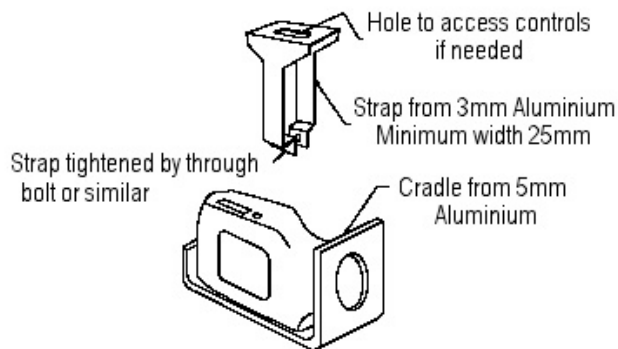

Diagram X

Competitors are reminded of SR203.8 and SR401.7

E18: GATES

Gate Marking.

All gates to be passed through during the event will be marked by a 20cm x 15cm (half A4 size) marker attached to a gatepost (not the gate itself). These will be put in place by the set up officials and removed by the recovery car. All gates will be called up in the road book together with an instruction “**leave closed**” (red) or “**leave open**” (green). Failure to comply with these instructions will result in a penalty under regulation 603.5.2. The marker will be demonstrated at the crew briefing.

The route instruction tulip lists all gates, and shows the way the gates are to be opened (towards or away) and on which side (left or right).

A yellow board with a black ‘G’ will be placed on the right hand side of the road 100m prior to a gate to advise drivers that a gate is ahead. However, drivers must not totally rely on this board being in place.

Gates on Transport Sections.

There are not a lot of these and they will not be marked. They will remain as found, and need to be opened and closed by competitors as required.

E19: PUBLICITY

Entrants, support crews, supporters, sponsors, the media and the public will be kept informed about the progress of the event and its winners and losers via the publicity service operated by the event’s Publicity and Promotions Manager Michael Browning, in conjunction with the event’s Results and Photographic team.

Results from each Day will be posted on the event’s website as soon as they are available while they will be joined by photographs of daily starts and special stage action by photographs taken by the Trial’s official photographer, John Douch.

Photographs of special media interest will be posted in high resolution on the Trial’s Media section of the website, where they can be accessed alongside regular articles covering the progress of the Trial, compiled by Michael Browning.

Entrants are encouraged to complete the ‘gossip’ forms issued with their Roadbooks to record any amusing, interesting or unusual aspects of their travels so that they can be shared with fellow competitors. These forms will be forwarded to the Publicity Manager for inclusion in event reports, keeping them interesting and lively for those following the Trial in the press or on the web.